

## Customer Support

Please visit the WeCreat Support Center for more setup, maintenance and application tutorials and questions.

<https://support.wecreat.com>

If you need more support, please try one of the following two options. We will get in touch with you as soon as possible.

1. Submit a support ticket at <https://support.wecreat.com>.
2. Directly send us an email: [support@wecreat.com](mailto:support@wecreat.com)

### Join Our Community.

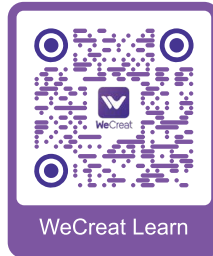

### Download WeCreat Makeit!



### Video Quick Start Guide

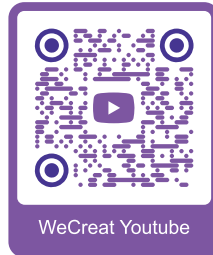

Let's Create with WeCreat!

[www.wecreat.com](http://www.wecreat.com)

# WeCreat Vision Laser Engraving & Cutting Machine



## USER MANUAL

Please review the entire guide before operating the device.

\*Safety Notice: Do not connect to power until setup is complete.



## Safety



**Warning: Do not leave the device unattended when in operation.**



If the machine operates with setting errors and is left unattended for an extended period of time, or if a mechanical or electrical fault occurs, it may lead to a fire.



**Keep explosive and flammable materials away from the device.**

Do not stack materials (such as paper) around the machine. They may cause the spread of flames and increase the risk of material ignition.



**Turn OFF device before plugging/unplugging.**



**Please do not lean on the machine top cover or place heavy objects on it.** As this will affect the balance of the machine and cause failure to the auto lifting function. When the machine is not in use for a long time, we recommend to adjust the machine to Idle mode or Transportation mode.



## Safety

### Please follow the operating principles:

1. Prior to each use, inspect the machine for any damage. Do not operate the machine if any damage or defects are detected.
2. Ensure that the workspace is clean and level.
3. Unauthorized disassembly or alteration of the machine's structure is strictly prohibited. Do not modify or decompile its operating system.
4. Maintain cleanliness inside the machine. Residues and debris accumulated during cutting and engraving can be hazardous and may cause a fire. Regularly remove chippings and residues.
5. Do not operate the machine when the lid is open. Always ensure the lid is closed before operating the machine.

WeCreat Vision is certified as a Class 1 laser product containing an embedded Class 4 laser module. The following label information applies to the WeCreat Vision product and its laser module.

### WeCreat Vision

## WeCreat Vision

Model Number: LC2320

Company Name: WeCreat Tech Limited

Supply Voltage: 100V-240V

Input: 24V  $\approx$  6A, 144W

FCC ID: 2AATL-6223A-SRD

Operating Temperature: 0 C ~ 40 C (32°F ~ 104°F)

Storage temperature: 0 C ~ 45 C (32°F ~ 113°F)

Made in China

Company Address: Room 501, Block 18 RuiYuan,  
TaoYuan District, Nanshan, Shenzhen



This device complies with Part 15 of the FCC Rules.

Operation is subject to the following two conditions:

- (1) This device may not cause harmful interference, and
- (2) This device must accept any interference received, including interference that may cause undesired operation.

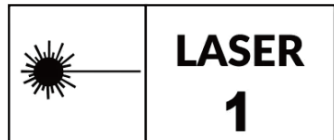

## Safety

### WeCreat Vision's Laser module



**Caution!** Use of controls or adjustments or performance of procedures other than those specified herein may result in hazardous radiation exposure.

### FCC Statement

This device complies with Part 15 of the FCC Rules. Operation is subject to the following two conditions:

1. This device may not cause harmful interference, and
2. This device must accept any interference received, including interference that may cause undesired operation.

**Warning:** Changes or modifications not expressly approved by the party responsible for compliance could void the user's authority to operate the equipment.

**Note:** This equipment has been tested and found to comply with the limits for a Class B digital device, pursuant to Part 15 of the FCC Rules. These limits are designed to provide reasonable protection against harmful interference in a residential installation.

## Safety

This equipment generates, uses, and can radiate radio frequency energy and, if not installed and used in accordance with the instructions, may cause harmful interference to radio communications. However, there is no guarantee that interference will not occur in a particular installation.

### EU Declaration of Conformity

Hereby, WeCreat Tech Limited declares that the radio equipment type WeCreat Vision is in compliance with Directive 2014/53/EU and Machinery Directive 2006/42/EC. The full text of the EU Declaration of Conformity is available at the following internet address:

<https://support.wecreat.com/hc/en-us/articles/8677731019151-WeCreat-Vision-EU-Declaration-of-Conformity>

### RF exposure statement

RF exposure information: The Maximum Permissible Exposure (MPE) level has been calculated based on a distance of  $d=20$  cm between the device and the human body. To maintain compliance with RF exposure requirements, use product that maintain a 20cm distance between the device and the human body.

This device may be used in each member state.

### Wireless Specifications

Bluetooth

Wireless Technology: BLE 5.0

Operating Frequency: 2402-2480MHz

Transmit Output Power:  $\leq 5$ dBm

2.4GHz Wi-Fi

Wireless Connectivity: IEEE 802.11b/g/n, up to 40MHz

Operating Frequency: 2412-2452MHz

Transmit Output Power:  $\leq 15$ dBm

### Main Specifications

Laser radiation output: 20 W

Wavelength: 450 - 460 nm / 645 - 660 nm

IEC 60825-1:2014

## Safety

<b>Dimensions</b>	<b>Rated Laser Power</b>
589*531*253mm - 589*531*393mm (23.19"*20.91"*9.96" - 23.19"*20.91"*15.47")	20W
<b>Package size</b>	<b>Max Engraving Speed</b>
750mm*630mm*400mm (29.53"*24.8"*15.75")	600mm/s
<b>Weight</b>	<b>Motion Accuracy</b>
Net weight: 19.34kg (42.637 lbs), Gross weight: 29.4kg (64.816 lbs)	0.01mm
<b>Electrical Requirements</b>	<b>Z-axis Movement</b>
100-240 VAC, 50/60 Hz Max: 140W	140mm (5.51")
<b>Air Assist</b>	<b>Laser head Lifespan</b>
30Kpa, 30L/min	10000h
<b>Auto lifting</b>	<b>Safety Guard</b>
140mm (5.51") without laser bed 100mm (3.94") with laser bed	Class I (FDA Certified)
	<b>Laser Spot</b>
	0.08*0.10 mm
	<b>Autofocus</b>
	Laser Radar



## Meet Your WeCreat Vision

For a video Quick Start Guide, please visit [wecreat.com/learn](https://wecreat.com/learn) or scan this QR code to view.

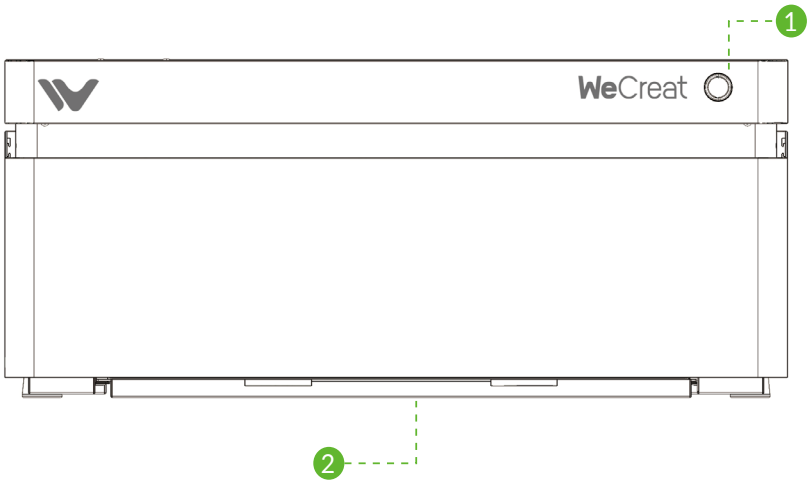
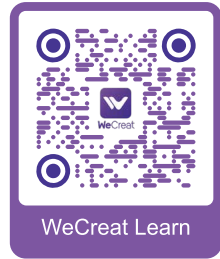

- 1 Start/Pause Button  
(Status Indicator:Blue-Idle, Green-Processing, Red-Error)
- 2 Detachable Tray

## Meet Your WeCreat Vision

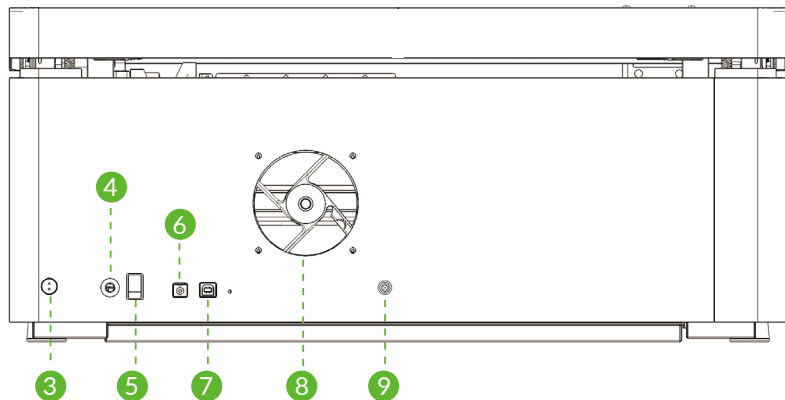

3 Air Assist Power Port    4 Air Assist Input Port    5 Power Switch

6 Power Port    7 USB Port    8 Exhaust Port

9 Wi-Fi Antenna Port

## Meet Your WeCreat Vision

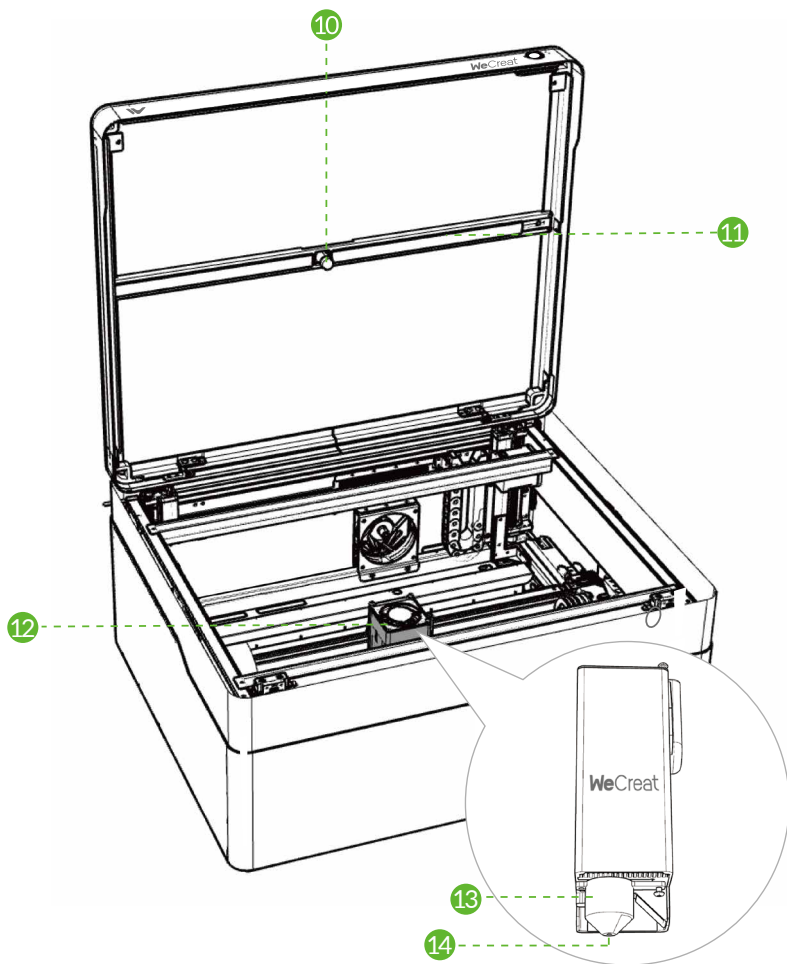

10 Camera

11 LED Strip

12 Laser Head

13 Air Nozzle

14 Laser Outlet

## What's In the Box

Unpack to take out the WeCreat Vision main product and check together with all included parts and accessories. If the product is severely damaged or any part is lost, please refrain from using it and get in touch with WeCreat customer service at [support@wecreat.com](mailto:support@wecreat.com).

Packaging methods may vary on different production batches.

### Package method 1

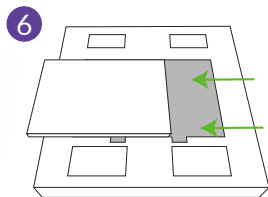
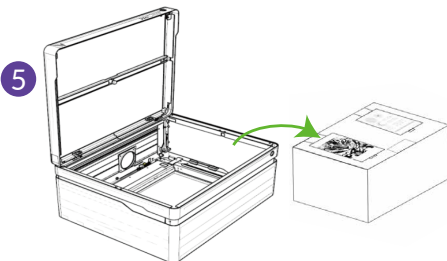
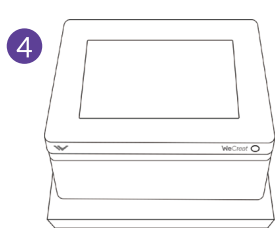
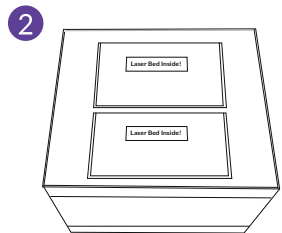
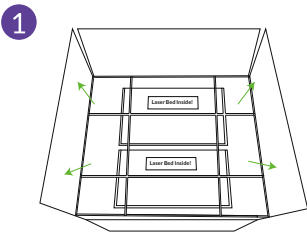

# What's In the Box

## Package method 2

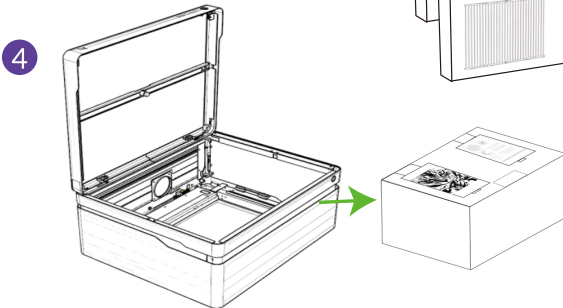
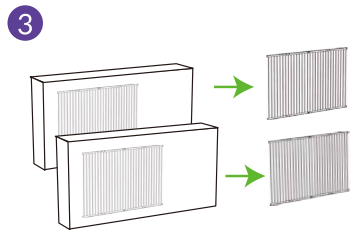
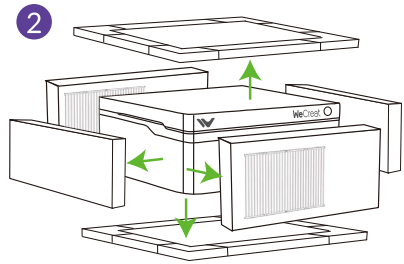
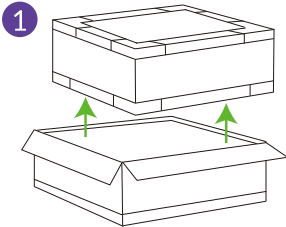

## What's In the Box

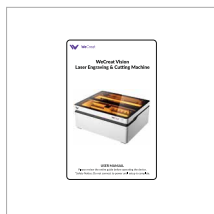

User Manual \*1

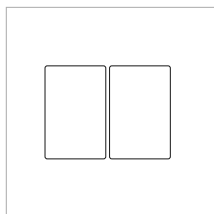

Sample \*2

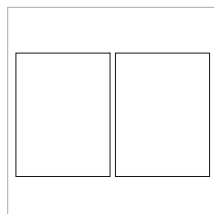

Basswood \*2

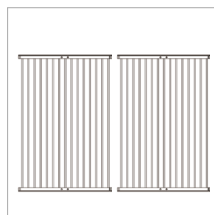

Laser Bed \*2

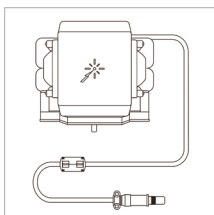

Air Assist Set \*1

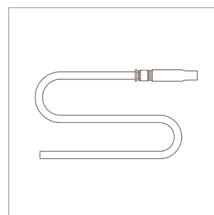

Air Assist Tube

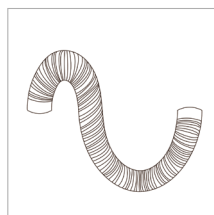

1.5m (4ft 11.05 inches)  
Exhaust Hose \*1

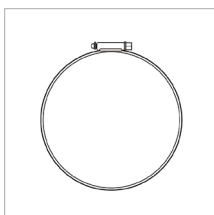

Exhaust Hose  
Clamp \*1

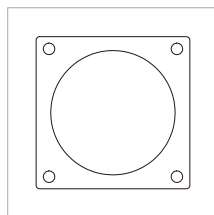

Exhaust Hose  
Connector \*1

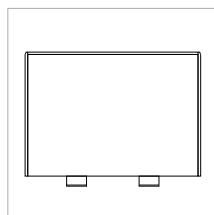

Detachable Tray\*1

## What's In the Box

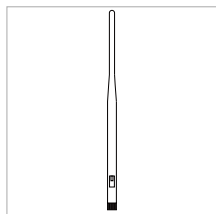

Wi-Fi Antenna \*1

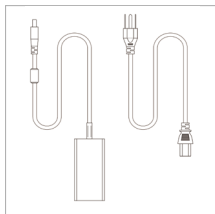

Power Cord \*1

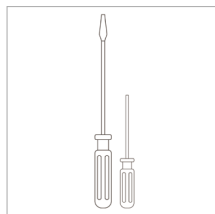

Screwdriver \*2

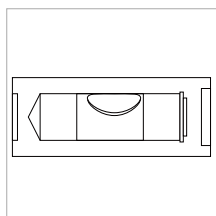

Mini Level\*1

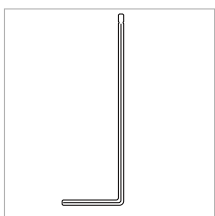

Hex Key \*1

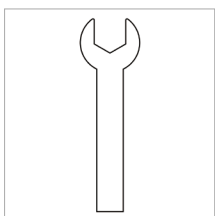

Wrench \*1

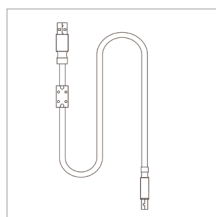

USB cable \*1

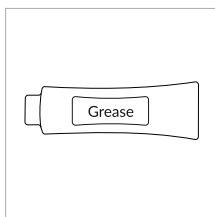

Grease \*1

 **Save the packaging!** If you would like to move your WeCreat Vision, or ship it (for example, for gift or warranty purpose), check this manual or our unboxing video to learn how to pack it in the right way. Only the original boxes and foams can ensure a safe transportation.

## What's In the Box

Available with WeCreat Vision Rotary/Premium Pack:

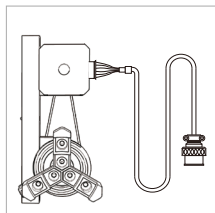

Rotary Set \*1

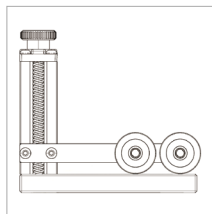

Rotary Holder \*1

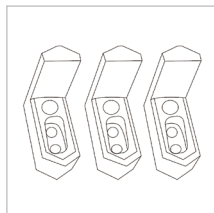

Single-step jaw component \*3

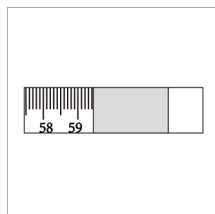

Tape Measure \*1

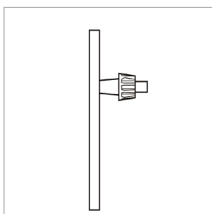

Chuck Key \*1

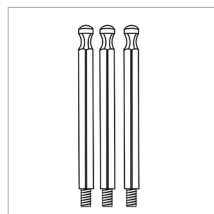

Threaded Stud \*3



## Product Setup

- 1 Install the exhaust hose connector with the small wrench and nuts supplied. Use the hose clamp to hold the exhaust hose.

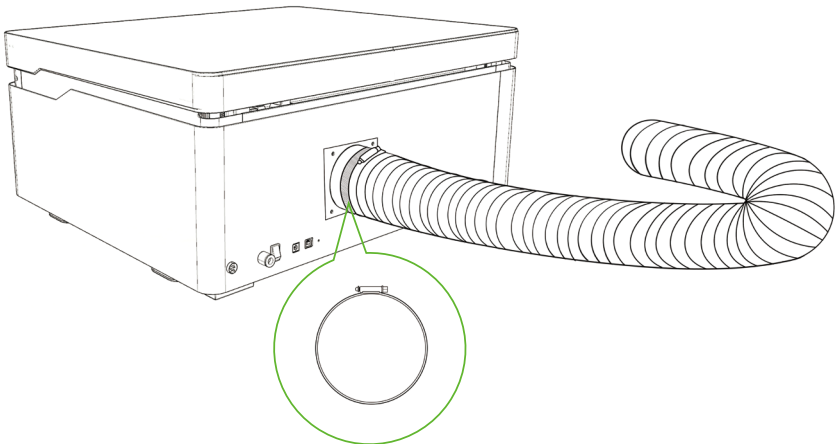
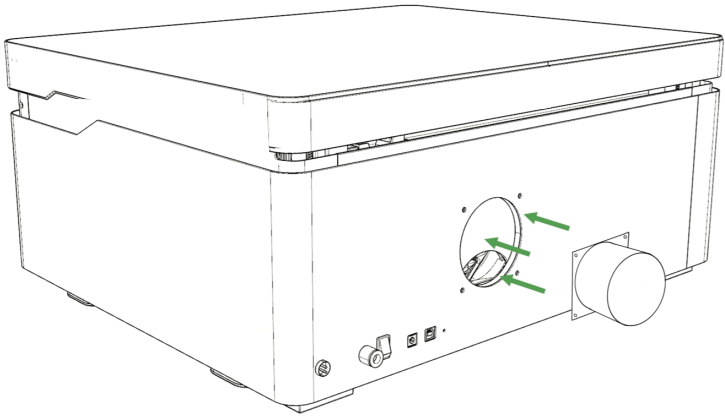

## Product Setup

- Put the other end of the hose outside of the window, or connect to the WeCreat Fume Extractor (sold separately).

**Note: When the WeCreat Vision is not in use, disconnect the hose from the machine or remove it from the window to avoid moisture/dust come into the machine and cause damage.**



Using an exhaust hose extension may weaken the exhausting capacity of the machine, resulting in smoke leakage.

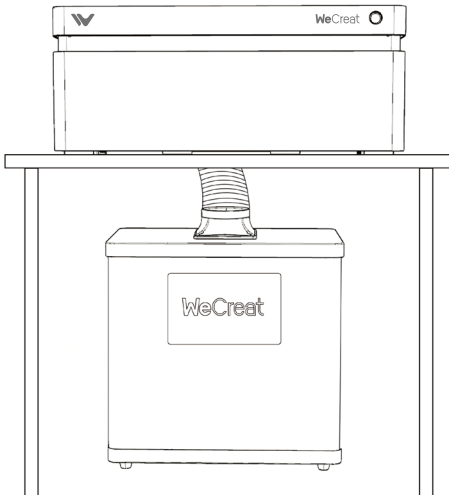
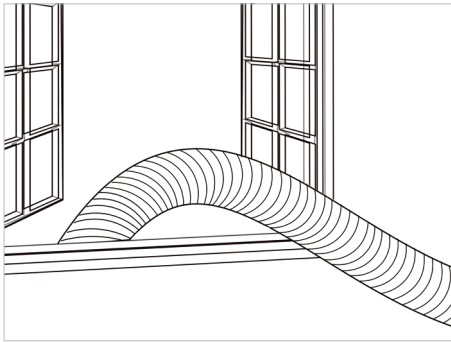

- 3 — Connect the Air Assist. Note: If you wish to unplug the air tube, press and hold the black annular valve to pull out the tube.

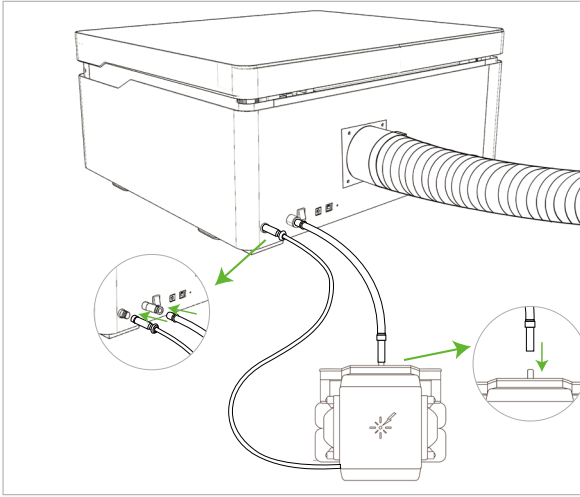

- 4 — Connect the Wi-Fi antenna.

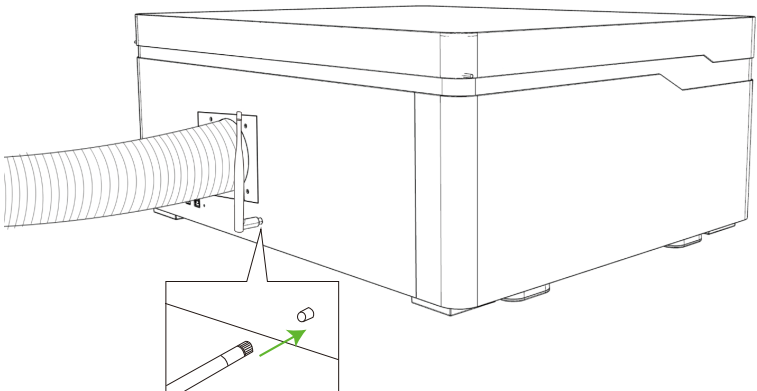

## Product Setup

- 5 — Insert the tray from the bottom of the machine along the guide rail.

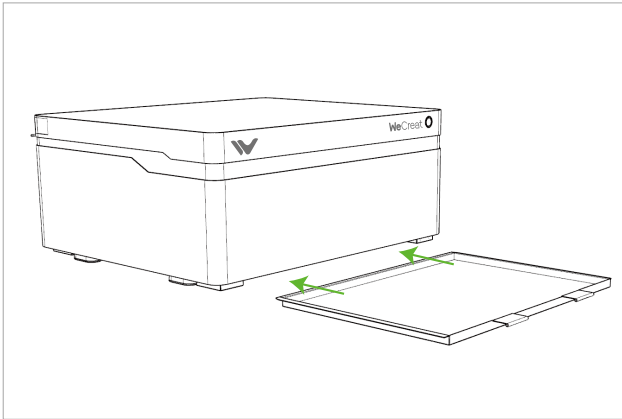

- 6 — Connect the power supply.

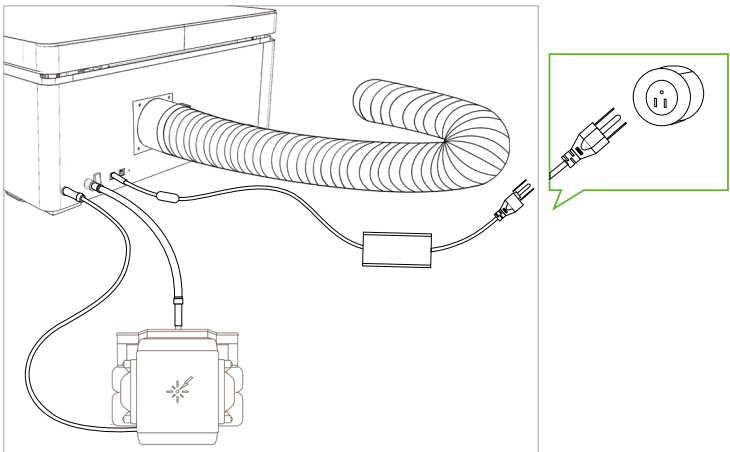

## Product Setup

- 7 Turn on the power switch. WeCreat Vision will power on, emit a beep, and then rise up.

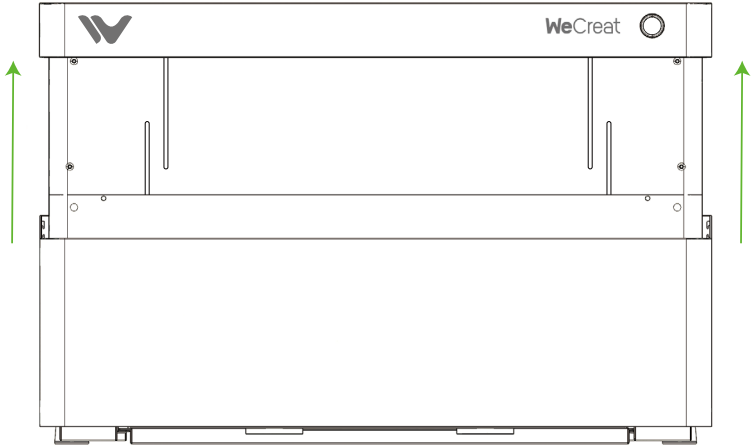

## Product Setup

- 8 Place the laser beds flatly into the compartment and make sure the detachable tray is in place.

**Note: Please make sure that the side of the frame with screws faces up.**

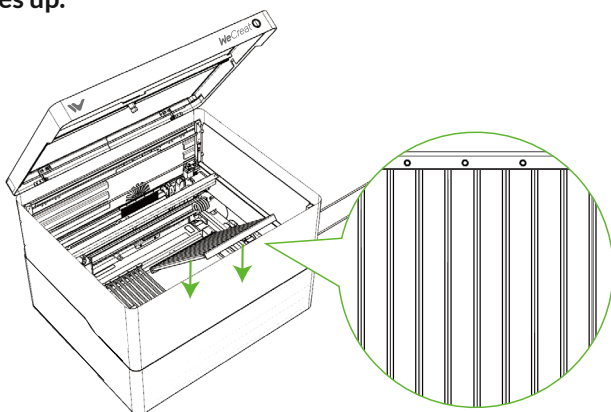

At this point, we have completed all the hardware installation steps. In the next chapter, we will introduce how to install and use the software.

However, in order to ensure that the machine does not have potential problems caused by pressure or impact during transportation, or if you encounter some abnormalities during the power on process, we recommend that you refer to Appendix 1 and Appendix 2 and do some check.

Appendix 1. Ensure the Z-axes are on the same plane-----40

Appendix 2. Ensure the Vision's X-axis is aligned-----44

You can also view the video tutorials by scanning the QR code.

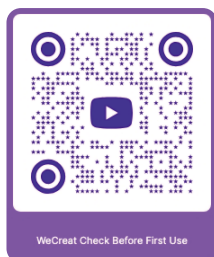

## Software and Network

1. Visit <https://wecreat.com/pages/software> on your computer and download the WeCreat Makeit! App. Click Yes when you are asked "Do you want to allow this app to make changes to your device?" and then continue the installation as prompted.

2. Use the supplied USB cable to connect the machine to your computer. Open the WeCreat Makeit! Software and click the 'Profile' button to create or log in to your WeCreat account.



## Software and Network

3. Once you have successfully logged in, click the New Project button.

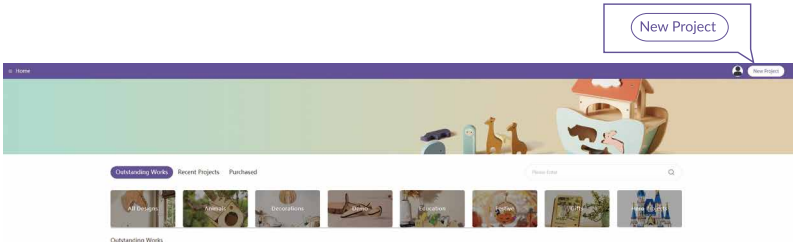

Note: For Windows operating system , it may ask you to install the USB driver first, please follow the prompts to finish the installation.

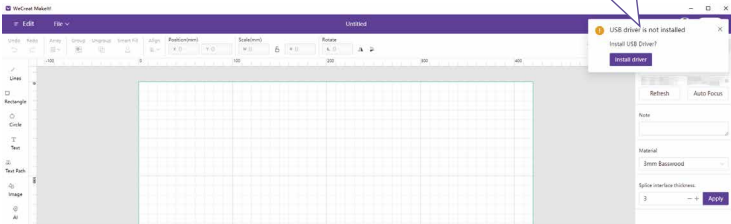
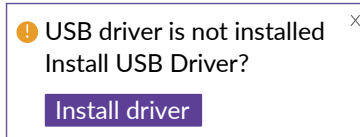



## Software and Network

4. In the device list of the right menu bar, you will see the device name with a USB icon, that means the machine is ready for USB connection, please click on it to establish the connection between the machine and your computer. Then you can start creating new projects.

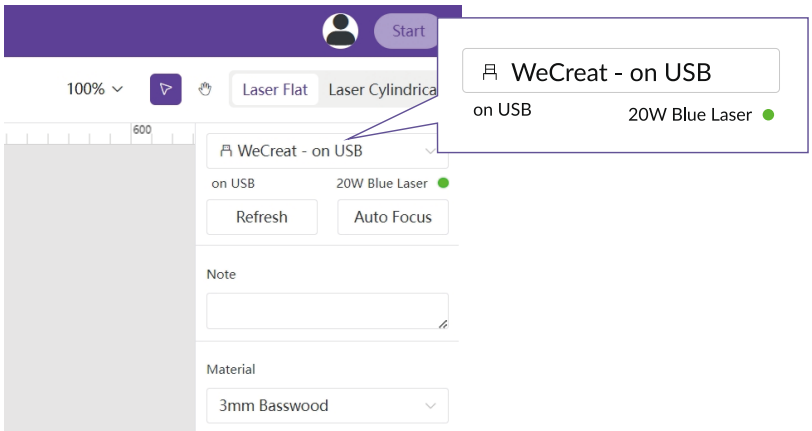
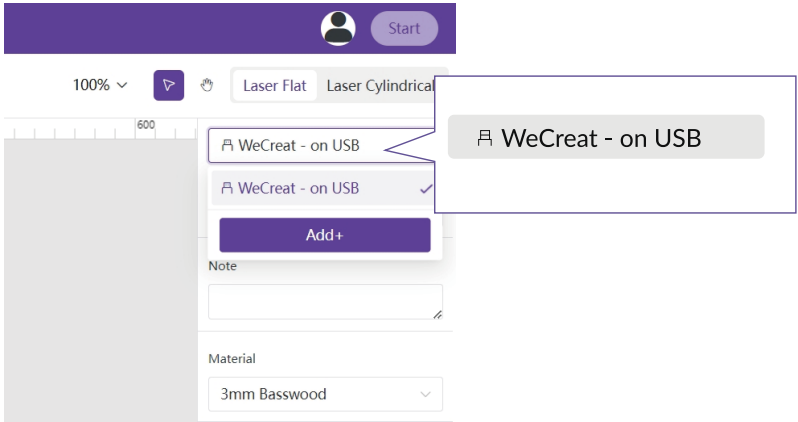

## Software and Network

5. You may wish to connect the WeCreat Vision via Wi-Fi instead of a USB cable connection. If so, please click the Settings button on the menu bar, and go to WiFi settings.

Note: Don't disconnect the USB cable until Wi-Fi setup is complete.

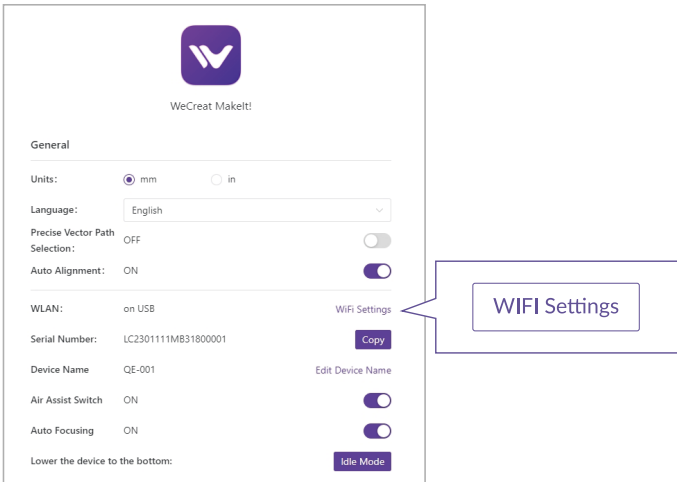

6. Select your home network and connect to it. Input your Wi-Fi password if required.

Note: This product doesn't support 5GHz Wi-Fi connection. Please ensure your Wi-Fi modem/router supports and has activated the 2.4GHz connection.

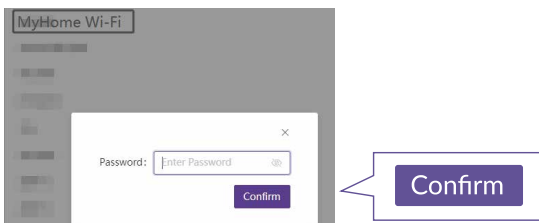

## Software and Network

7. When you see the message “Wi-Fi connected successfully”, close the settings window. Then you will see the machine is shown in the device list with a green dot on the right side, which means you are now connected to Vision wirelessly, eliminating the need for a USB connection.

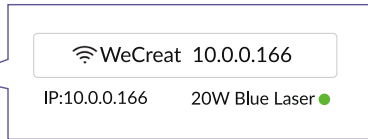
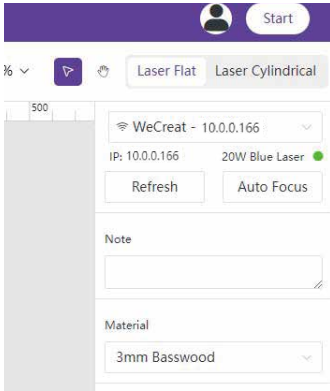

**Note:** Sometimes due to the compatibility issue with specific Wi-Fi modem/routers, issues may arise with showing the machine's name in the device list, in that case you can manually add the device as follows:

- ① Keep the USB cable connected between your computer and WeCreat Vision.
- ② Open the Settings window, find the WLAN IP address, and write it down.



WeCreat Makell!

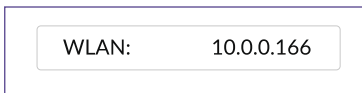
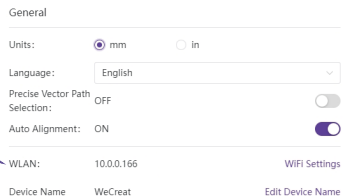

## Software and Network

③ Navigate to the right side menu bar, click on the device list and click Add+. In the pop-up window, click on IP address tab, put in the IP address which you have just written down, then click Connect.

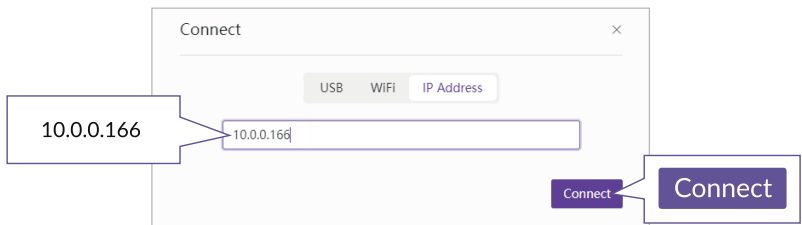
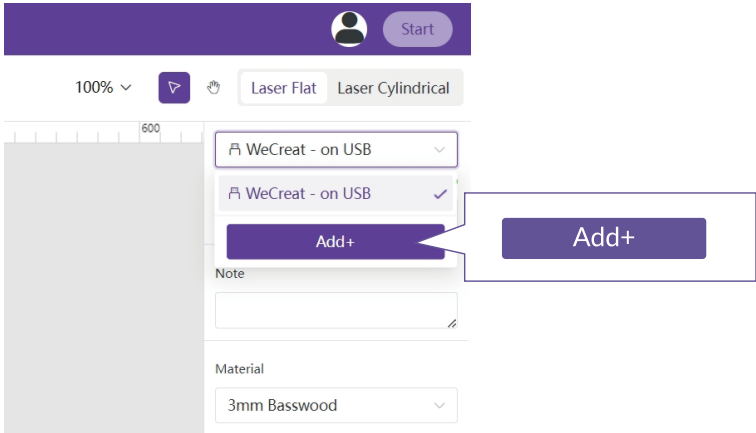

## Software and Network

④ Now please check if the wireless connection is established.

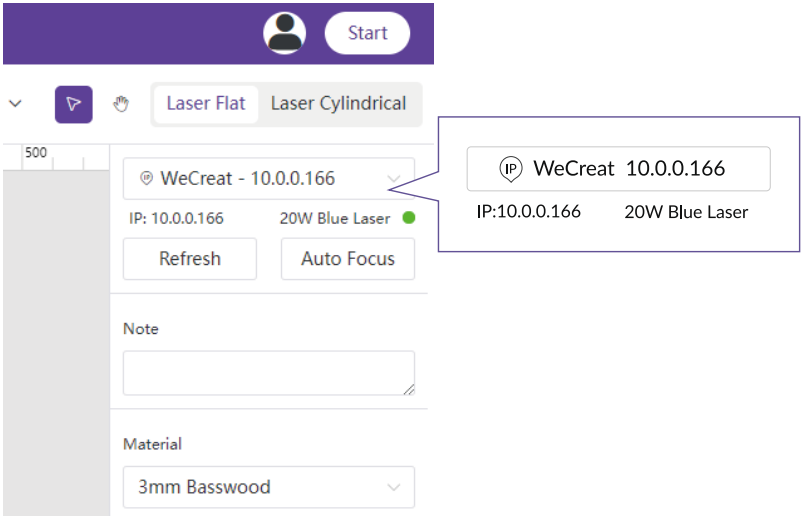

The screenshot shows the WeCreat software interface. At the top, there is a purple header with a user profile icon and a "Start" button. Below the header, there are two tabs: "Laser Flat" (selected) and "Laser Cylindrical". The main interface displays the following information:

- Device name: WeCreat - 10.0.0.166
- IP: 10.0.0.166
- Power: 20W Blue Laser (indicated by a green dot)
- Buttons: Refresh, Auto Focus
- Note: A text input field for notes.
- Material: 3mm Basswood (selected in a dropdown menu)

A callout box highlights the detected IP address and device name, showing:

- IP: 10.0.0.166
- 20W Blue Laser

If you still encounter issues with establishing the Wi-Fi connection, please feel free to contact us at [support@wecreat.com](mailto:support@wecreat.com), our helpful and friendly support engineers are just one click away!

## First Project

1. Open the software WeCreat Makelt! on your computer, and click on **New Project**.

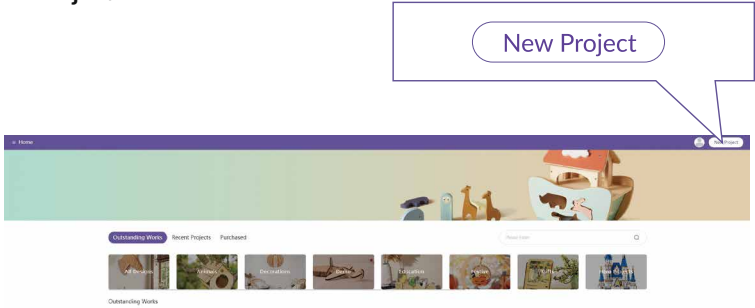

2. Select **Text** in the left side menu, then click on the canvas to insert the text. You can double-click the text area to edit it, or drag it to zoom in/out and adjust its position.

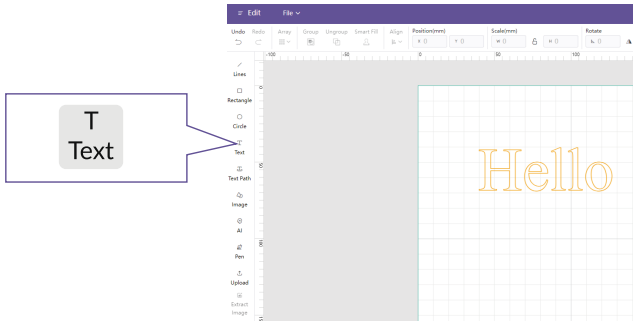

3. Select **Circle** in the left side menu, then drag and draw a circle around the text area.

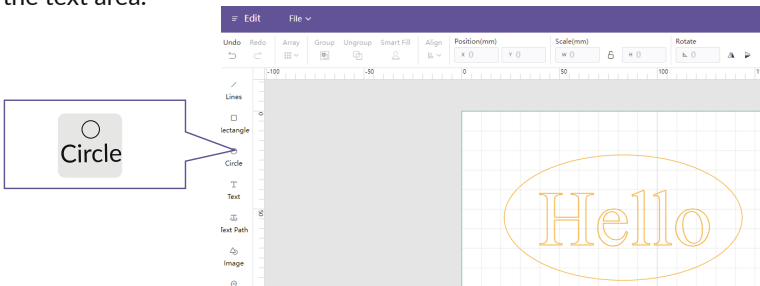

## First Project

4. Open the the machine's lid and place the supplied 3mm Basswood on the laser beds. Click the **Refresh** button on the right-side menu to display the actual background. You can then drag the text to your desired location.

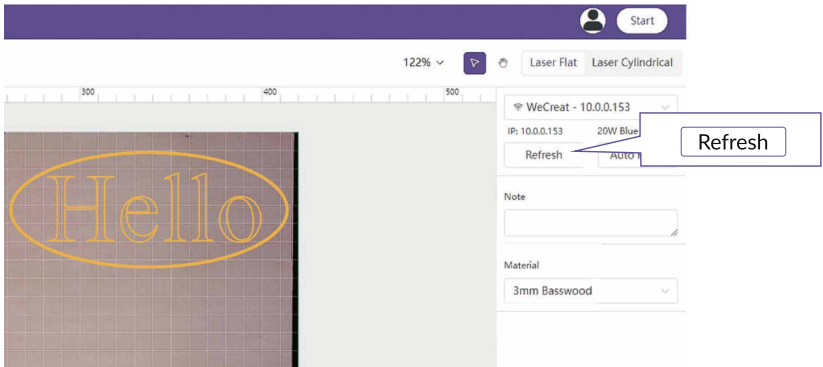

5. Drag the mouse to select the text and circle, choose **Engrave** on the right side menu, adjust the Power and Speed settings accordingly, or simply keep the default settings. Then click the **Auto Focus** button, the machine enclosure will descend, the laser module will move to the desired location, then return to the top left corner.

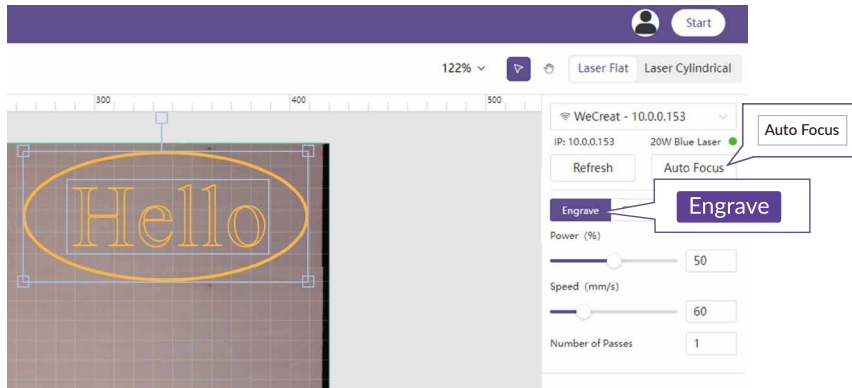

## First Project

6. Click the **Start** button, check the preview and estimated processing time in the pop-up window and click **Send**. Then, when you are ready to begin engraving or cutting, press the physical button on the machine to start the job.

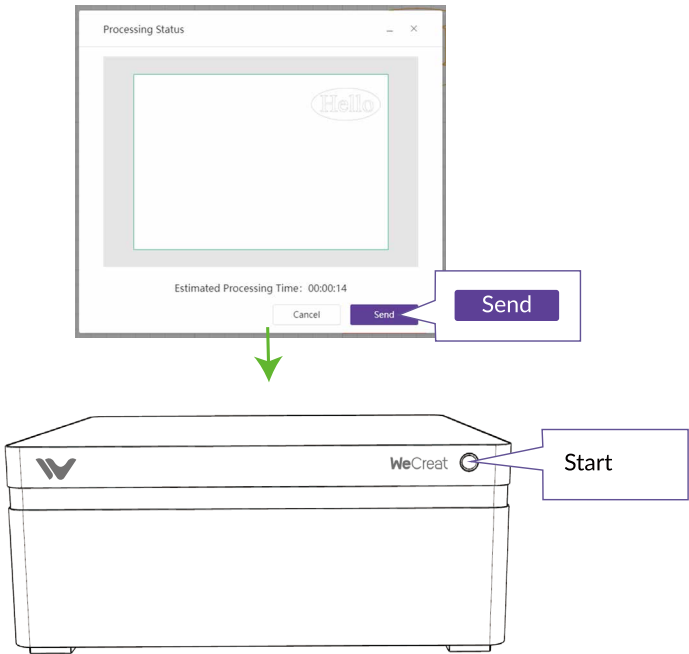

7. Wait until the task is finished, then open the top lid to meet your first project.

If you'd like to learn more about how to create advanced projects, please visit our online learning center at [wecreat.com/learn](http://wecreat.com/learn)



## Using the Rotary Set

**\*Applicable to WeCreat Vision Rotary/Premium Pack only.**

For a video guide of how to install the Rotary Set, please visit [wecreat.com/learn](http://wecreat.com/learn) or scan this QR code to view.

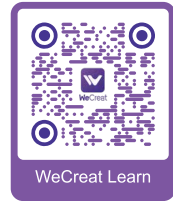

1. Before we start, please use the supplied tape measure to get the perimeter/diameter of the cylindrical object you want to engrave.

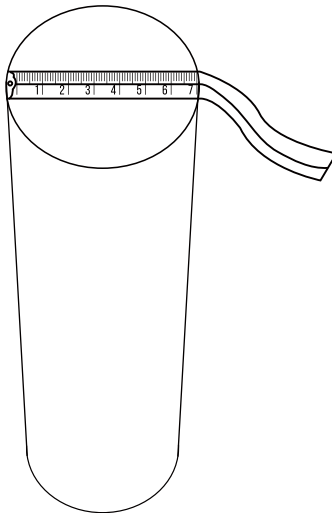
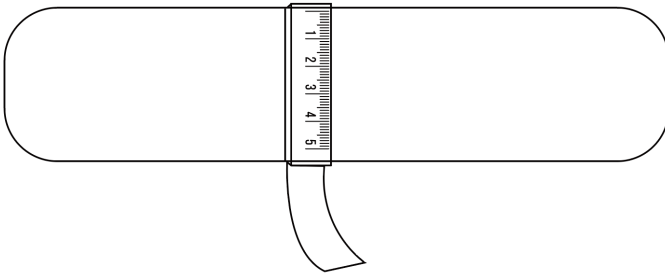

## Using the Rotary Set

2. Take out the laser beds and the two screws on the frame which will be used to secure the Rotary set.

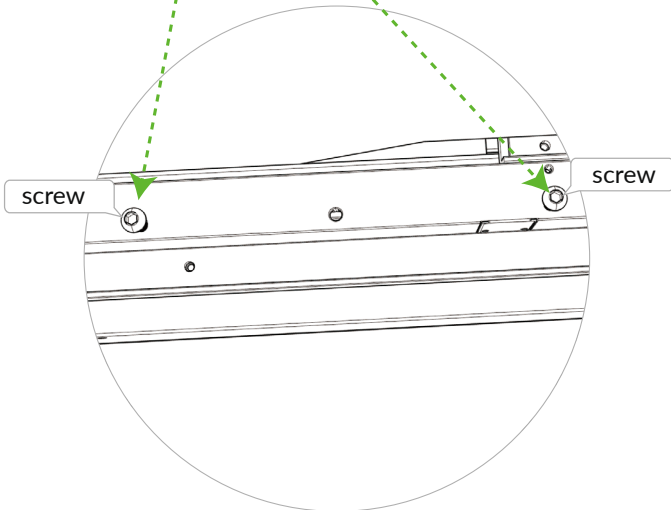
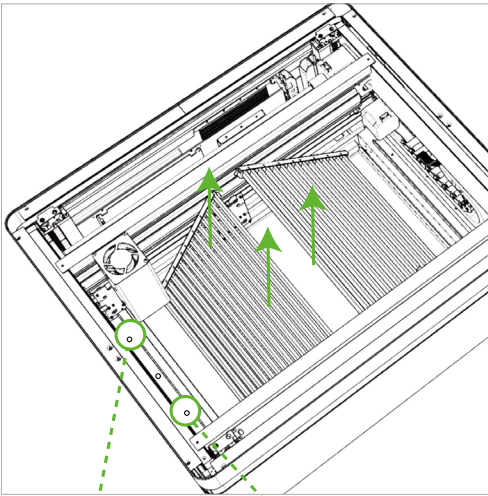

## Using the Rotary Set

3. Put the Rotary Set onto the left frame of the machine. Make sure the middle locating pin of the Rotary Set aligns with the locating hole on the left frame of the machine.

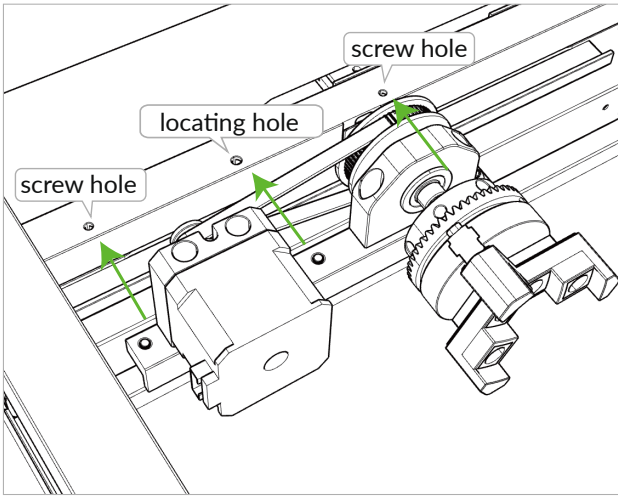

4. Then use the hex key and hex screws to fasten the Rotary Set.

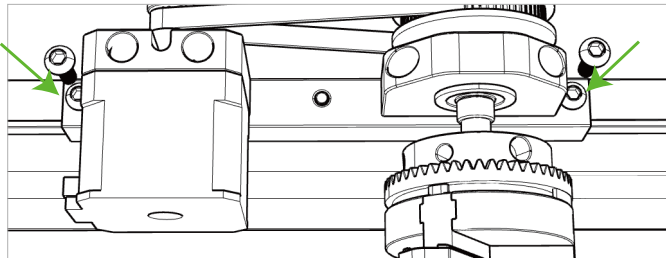

## Using the Rotary Set

5. Plug the connection cable into the port on the machine's control board. Make sure to align the connector with the groove in the port.

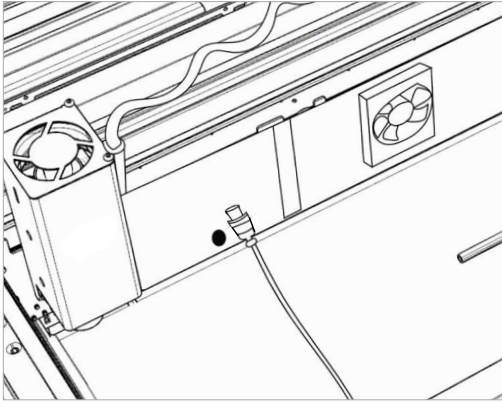

6. Place the cylinder you want to engrave onto the jaw chuck, tighten the jaw chuck with the chuck key.

Note: There are three holes for chuck key on the base. Use the chuck key on all three holes to ensure the cylinder is firmly fixed.

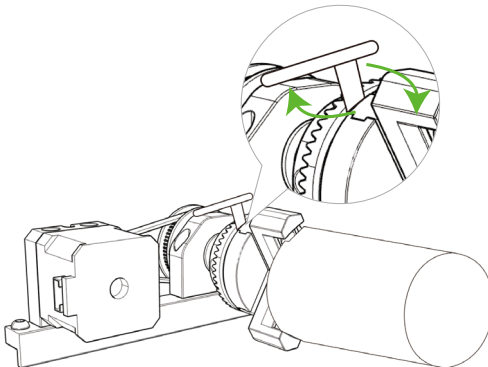

## Using the Rotary Set

7. Place the Holder part underneath the cylinder, spin the top wheel to adjust the height of the holder to ensure the cylinder is supported. You can use the supplied mini level to check if the cylinder is horizontally fixed.

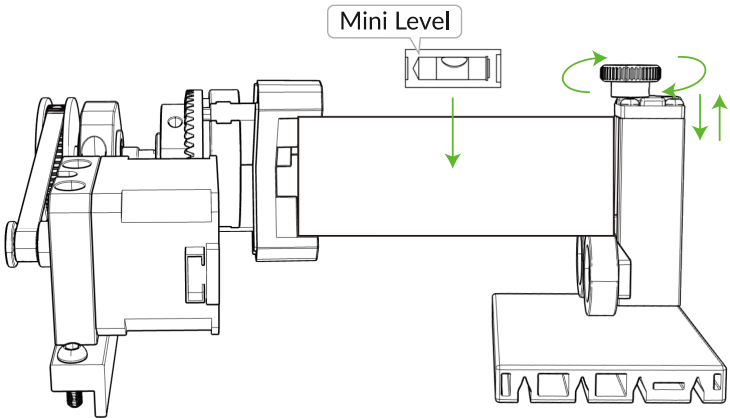

8. If you would like to engrave on small objects such as rings, please take out the six screws and remove the jaws, then install the three threaded studs on the jaw chuck.

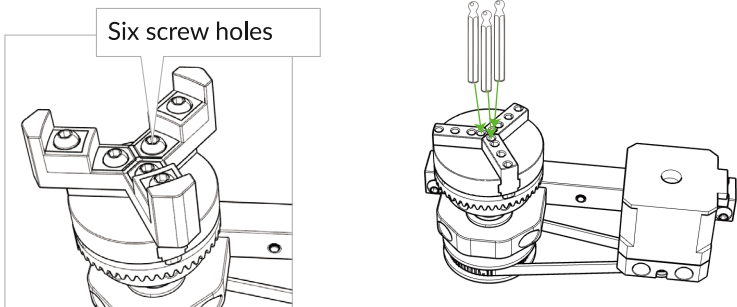

## Using the Rotary Set

9. Open the WeCreat Makelt! software, select Laser Cylindrical mode on the top right corner, it will show an image of the cylindrical object. Put in the Perimeter/Diameter you got in the beginning.

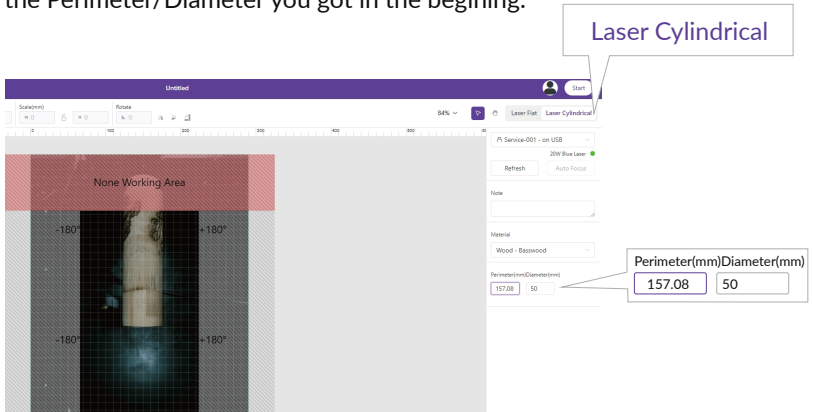

10. Put your design (text/vector/image) on the desired position of the cylindrical object, choose the working mode (Engrave/Fill Engrave) and power/speed parameters, then click Start to get the preview.

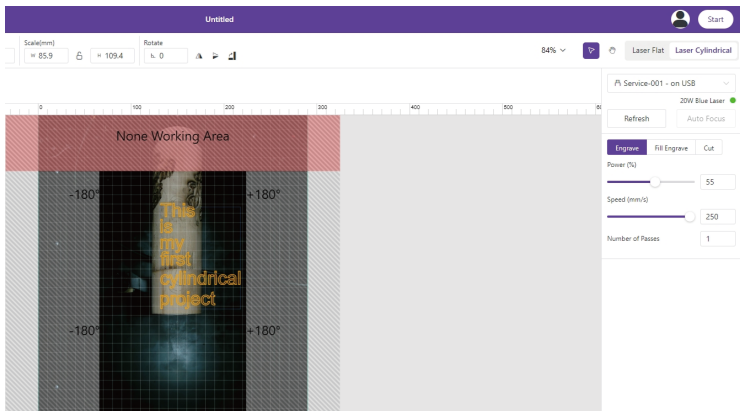

11. Click Send and press the Start/Pause button on the machine. Wait until the task is finished, the top lid will rise up and you can now open it to meet your first cylindrical project.

## Using the Rotary Set

### Tips about the jaw chuck:

1. In its default status, it can be used for cylinders with diameters between 1 - 100 mm (0.039 - 3.93 inches).

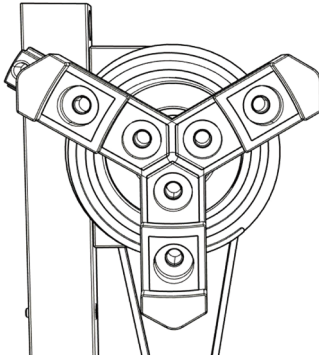

2. Please ensure that the Rotary connection cable passes through the groove on the rack below the chuck jaws. If it is placed directly above or below the cylinder to be engraved, the cable may be damaged by the laser.

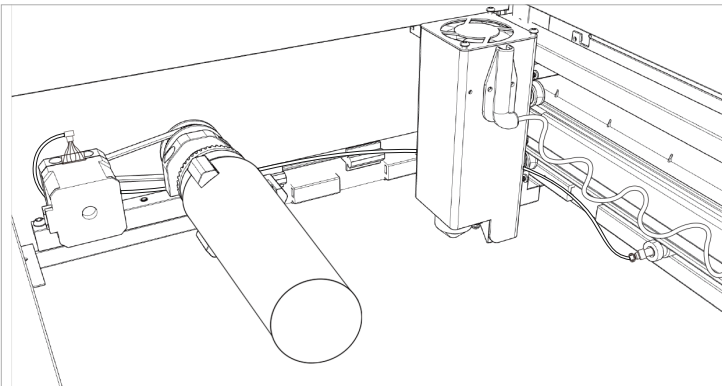

## Maintenance

Please scan the QR code to view all the cleaning and maintenance steps below.

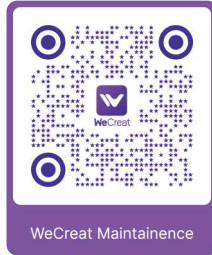

### 1. Fan maintenance.

After prolonged use, if you notice significant dust accumulation on the cooling fan of the laser module and the exhaust fan at the rear of the machine, we recommend cleaning the relevant areas.

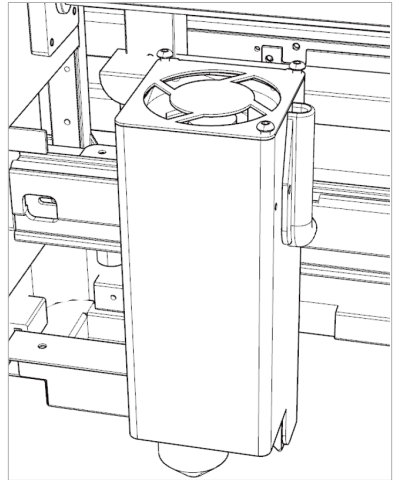
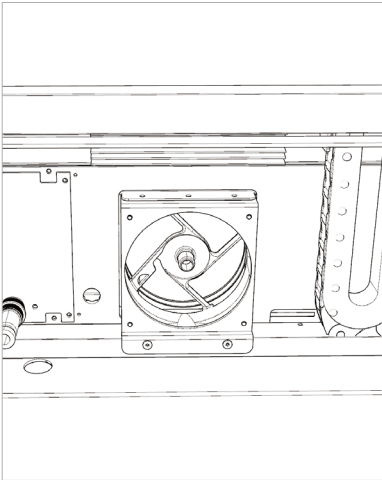



## Maintenance

### 2. Laser head maintenance.

We have a built-in air pump to blow away the smoke during lasering, so in general, the laser lens will not be contaminated. However, if the air pump is manually turned off frequently, or if you meet auto-focus failure or insufficient laser power issue, please clean the lens at the bottom of the laser head.

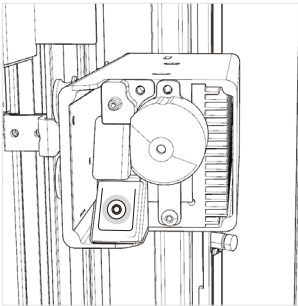

### 3. Clean the inside of the laser module.

After prolonged use, if you notice abnormal movement of the laser module, such as continuously hitting the frame, it may be caused by dust accumulation on the internal limit switch. We recommend cleaning the relevant parts.

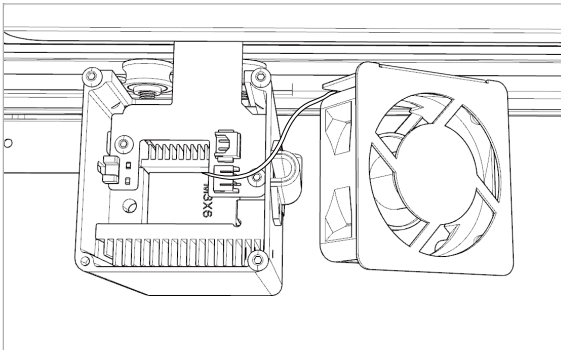

## Maintenance

### 4. Grease the X axis and Z axes

The X axis slide bar and Z axis threaded studs need to be greased periodically to maintain top performance. We recommend applying grease to them once every 120 hours of cumulative operation time of WeCreat Vision.

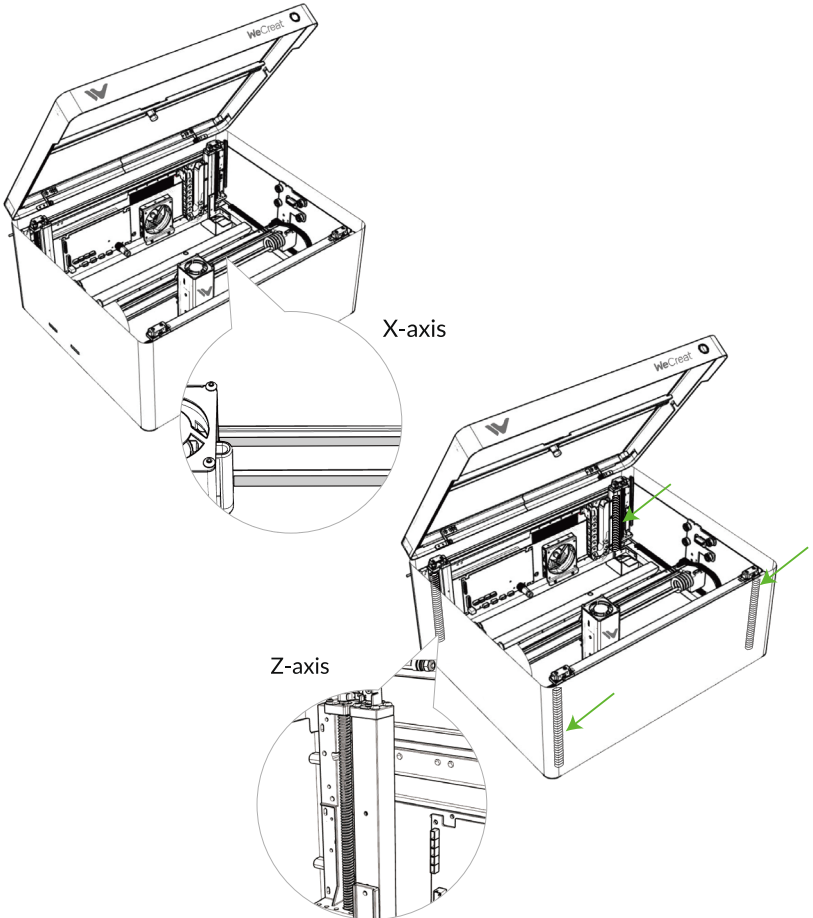

## Appendix

### Appendix 1. Ensure the Z-axes are on the same plane

Sometimes if the machine is heavily bumped or pressed during transportation, it will result in the top of the four Z-axes not being on the same plane, and cause abnormal noise issue during rising/lowering or the machine is even unable to move up/down. In this case, we recommend you to adjust the Z-axes manually.

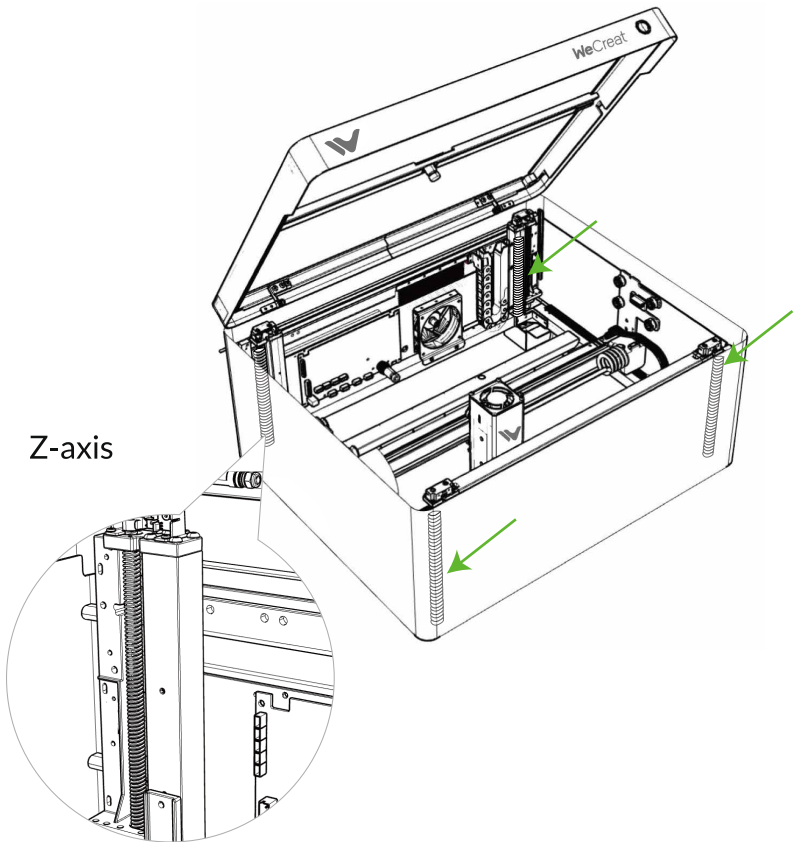

## Appendix

1. Power OFF the machine first!

2. Use a straight screwdriver to adjust the screws on the four corners. Try the four screws one by one to see if all four screws can be easily turned, which means the Z-axes are in place.

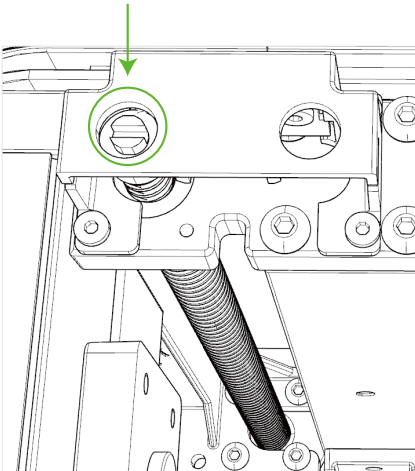
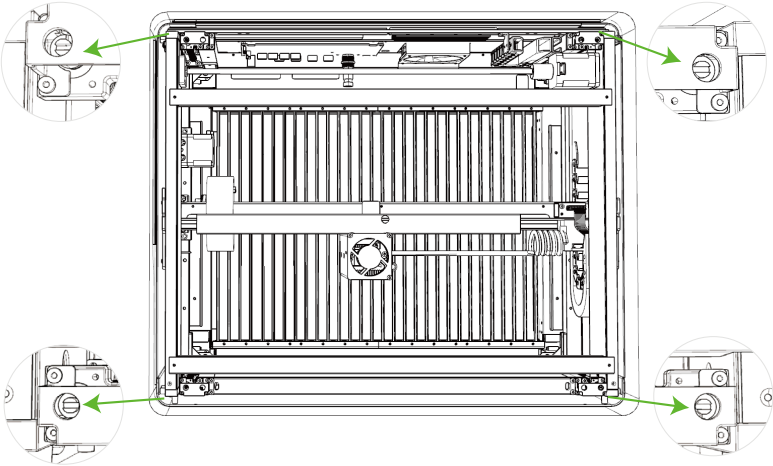

## Appendix

3. If one of the screws is difficult to turn, it indicates that the corresponding Z axis may be stuck. You may also use the supplied mini level to measure and see which corner is higher/lower. Please place the level on the four corners and frames as shown below.

Note: Make sure the desk is level first. Otherwise, please don't use the level to measure the laser.

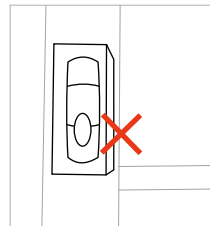
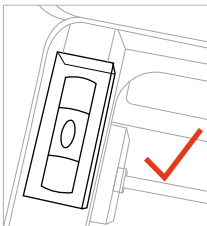
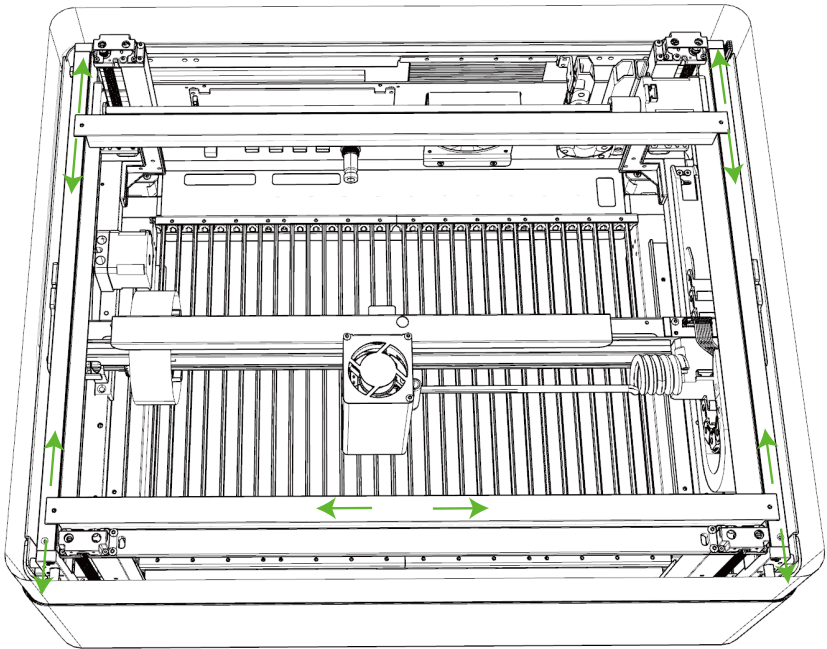

## Appendix

4. After confirming which Z-axis is stuck, rotate the screws of the other three Z-axes to raise/lower them to the same height as the stuck Z-axis. At this point, try to turn the screw of the previously stuck Z-axis, and it should be easy to turn it.

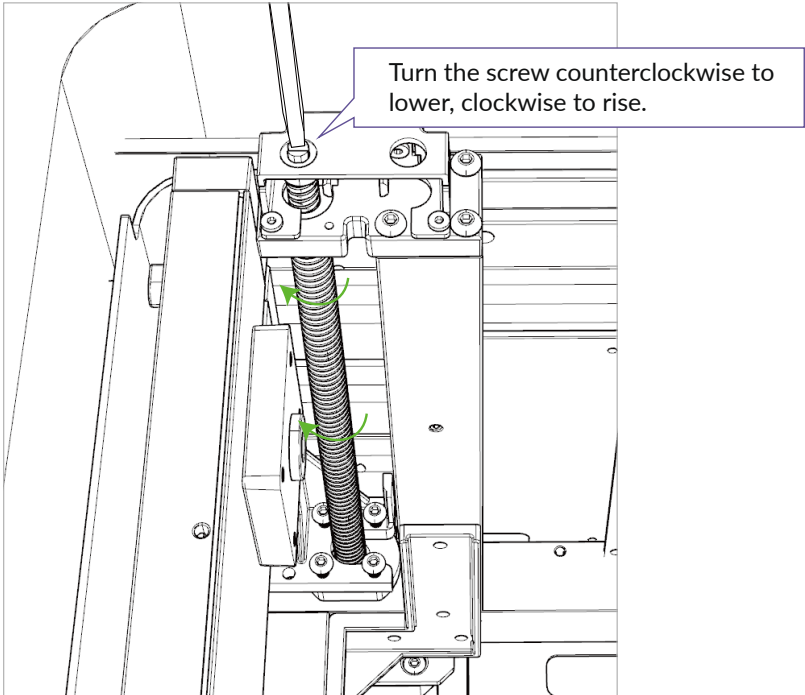

5. Ensure the four screws are all easy to turn, now you can power on the machine, and check if it moves up/down freely when powering on, doing auto-focus or switching to Idle/Transportation mode.

## Appendix

### Appendix 2. Ensure the Vision's X-axis is aligned

Due to pressure or impact during transportation, the position of the X axis may be offset, which may cause abnormal startup or skewed engraved patterns. You can confirm whether there is an X-axis offset by the following method.

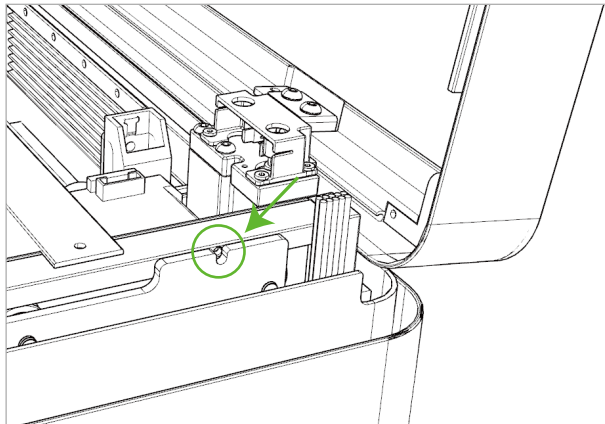
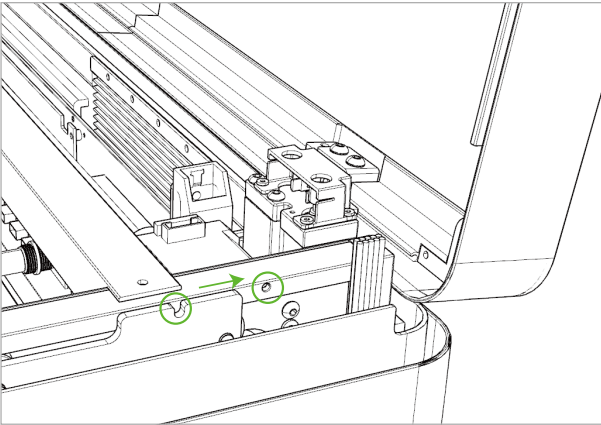

## Appendix

To solve the issue of misaligned X-axis, please try the following steps.

1. Power off the machine first. Loosen the two screws on the metal rod shown in the picture below.

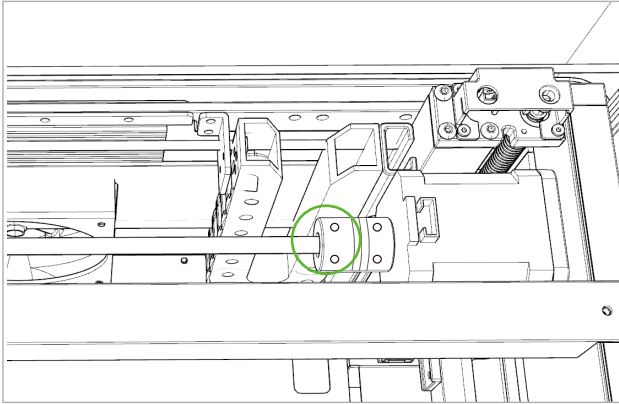

2. Push the metal rod on the misaligned end inside to make the positioning hole coincide with the one on the frame.

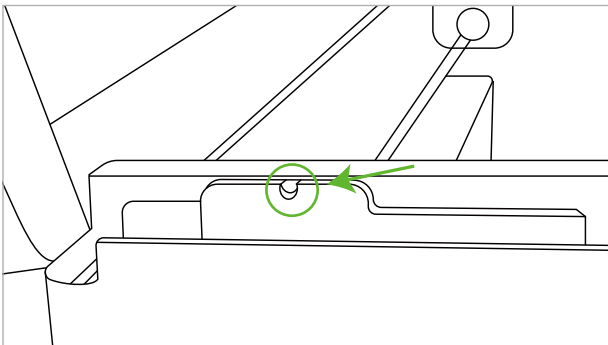



## Appendix

3. Once aligned, secure the two screws.

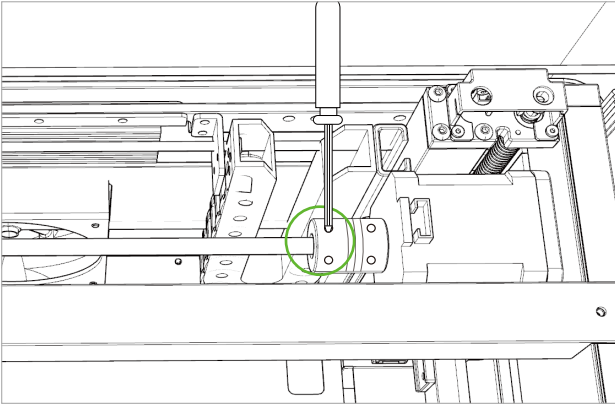

Scan the QR code to get video tutorials of the above steps.

